

Dairy Technology



Product
brochure

A black and white cow is the central focus of the image, standing in a lush green field. The cow is facing left, and its body is covered in characteristic black spots on a white background. The background shows a clear blue sky and a distant treeline. The overall scene is bright and natural, suggesting a healthy and happy environment for the cow.

Boetech was founded in 1997, inspired by the first prototype of the Lely Astronaut milking robot. We offer innovative, efficient and reliable highly quality products that add value to your automatic milking system.

Over the years we have built up a wide range of products. Our committed and innovative approach is based on 25 years of experience. Milk quality, cow friendly products and free cow traffic form the foundation of our policy, and are at the basis of the development of new products. Free cow traffic means the cow can eat, drink and get milked without hindrance, whenever the cow wants to. At each stage of production rigorous quality tests are carried out by the experts to ensure the best equipment. Clean drinking water is important for the health of the cow and the milk production: 85% of milk consists water. The more clean water the cow drinks, the better the health of the cow and thus indirectly the milk quality.

We collaborate with dairy farmers to create sustainable and cost-effective products that meet our business goals. The company's success was and is based on efficiency and optimization.

For more than twenty years we have been certified installer of the Lely Milk robot in the Benelux. We are proud of our bond with international dairy farmers and our continuing international growth.

A healthy, happy cow results in a satisfied farmer and a higher milk yield, with better milk quality!

Table of contents

1. BUFFERTANKS

Buffertanks

Buffer valve systems

Switch boxes

Pressure systems

2. TANK ADJUSTMENTS

Swan neck

3-way valves

Milk drain

Tank valve connections

3. MILKLINE CONNECTORS

Clamp

Pex

Silicon

4. BETWEEN ROBOT AND TANK

Duo filters

Water systems

Non-return valves

Pipe heat exchanger

4

4

6

8

9

10

10

11

12

13

20

28

28

30

33

34

1. Buffertanks

We have designed and manufactured buffer tank systems in various sizes and models to meet specific requirements.

Milk cooling is essential to remain the milk quality. Refrigerating milk on the farm has two main aims, to inhibit bacterial spoilage and to extend storage on the farm. Boetech offers highest quality buffer tanks to meet your storage demands. The buffer tank is placed between the milking system and the main milk tank.

The robot remains in fully operation whilst the main tank is emptied and cleaned, avoiding interruptions for the cow its natural rhythm. This gives you the opportunity to have a visual final check of the main tank. The buffer tank will get emptied through gravity.

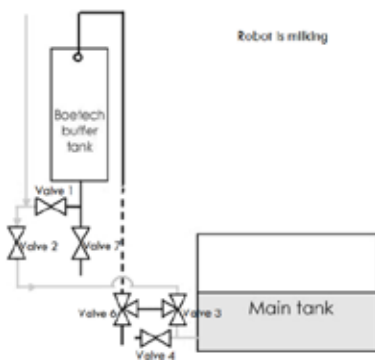

Robot is milking

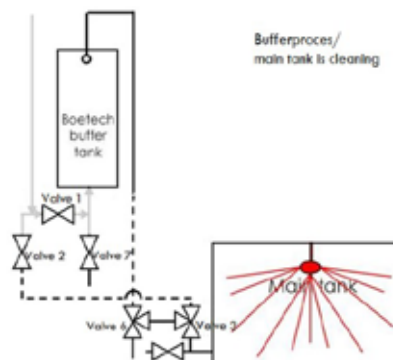

Bufferproces/
main tank is cleaning

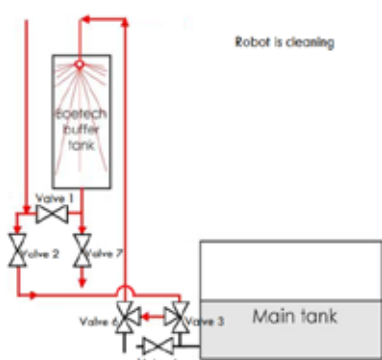

Robot is cleaning

Milk goes directly into the mechanically refrigerated main tank.

Milk goes into the buffer tank. The main tank is being cleaning and rinsed.

The robot, milk pipeline and buffer tank are being cleaned. Milk is stored in the mechanically refrigerated main tank.



Advantages

- Makes continuous milking possible, so the milking rhythm is not disturbed; ensures smooth operation.
- Compact. The tank can be integrated into every situation.
- Environment friendly.
- No yearly maintenance costs, because the buffer system does not have a milk pump or cleaning system.

Requirements main tank

- The main tank must be equipped with an automatic cleaning system.
- The inlet of the main tank has to be at least 20cm below the outlet of the buffer tank (the higher the better).

Number of robots	1-2	3-4	4-8
Typ buffer tank l	250, 350	500, 650, 800	1200, 1600

Example situation

Number of robots: 3

Maximum milk production robot/per hour: 120 kg

Loading time milk truck + cleaning milk tank: 1,25 hour

3 robots x 120 kg x 1,25 hour = 450 L. = Type buffer tank 500

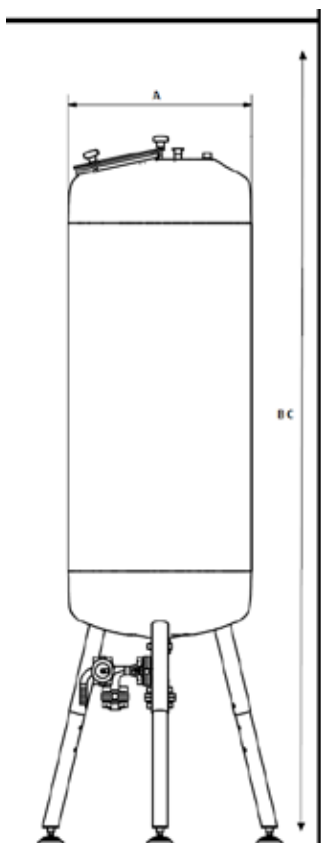

Description	A	B	C
250 Standing model	60 cm	230 cm	260 cm
250 Wall model	50 cm	230 cm	260 cm
350 Standing model	60 cm	220 cm	250 cm
350 Wall model	60 cm	220 cm	250 cm
500 Standing model	98 cm	190 cm	220 cm
500 Wall model	60 cm	290 cm	320 cm
650 Standing model	98 cm	230 cm	260 cm
800 Standing model	98 cm	230 cm	260 cm
1200 Standing model	95 cm	280 cm	310 cm
1600 Standing model	140 cm	240 cm	300 cm

A = Diameter tank

B = Minimum height ceiling milk storage room

C = Advised height ceiling milk storage room. Note: Minimum distance between the top of the buffer tank and the ceiling should be 30 cm, for inspections.



BUFFER VALVE SYSTEMS

With this fully automated system, milking can continue during cleaning of the main tank, optimizing the robot's capacity.

Boetech offers a various range buffer valve systems in the DN20, DN25 and Configuration H edition. The graph below will show you what type buffer valve system we recommend in combi with a buffer tank.

Dairy farmers with more than 3 robots we highly recommend to use the larger double valve systems. A double valve system is to use when you have two different clusters of robots: milking meet specific requirements.

	Standing model 250	Wall model 250	Standing model 350	Wall model 350	Standing model 500	Wall model 500	Standing model 650	Standing model 800	Standing model 1200	Standing model 1600
Single valve DN20	202011	202010	202021	202020	202030	202029				
Single valve Level sensor DN20	202012	202013	202022	202023	202032	212021				
Double valve Level sensor DN20					202033	212024	212142	202041	202050	202060
Single valve Level sensor DN25					212032	212022	202036	202042	202053	202059
Double valve Level sensor DN25								212045	202051	202061



Not possible

Available, but not recommended





Available

SV = Single valve system
 DV = Double valve system
 LS = Level sensor

SM = Standing model
 WM = Wall mo

MAINTENANCE SETS

Valve system type	Buffer tank type							Sealing set
	250	350	500	650	800	1200	1600	
Single valve DN20								214515
Single valve DN20 + level sensor								214513
Double valve DN20 + level sensor								214517
Single valve DN25 + level sensor								214514
Double valve DN25 + level sensor								214518

Sealing set	Contains			
214515	3 x EPDM seal 1"	100121		
	1 x EPDM seal 1,5"	100122		
	3 x Tri-Clamp seal DN 20	201079		
	1 x Tri-Clamp seal 2"	201072		
214513	3 x EPDM seal 1"	100121		
	1 x EPDM seal 1,5"	100122		
	3 x Tri-Clamp seal DN 20	201079		
	1 x Tri-Clamp seal 2"	201072		
	1 x Silicone seal (levelsensor)	203021		
214517	5 x EPDM seal 1"	100121		
	1 x EPDM seal 1,5"	100122		
	5 x Tri-Clamp seal DN 20	201079		
	1 x Tri-Clamp seal 2"	201072		
	1 x Silicon seal (levelsensor)	203021		
214514	3 x EPDM seal DN25	100123		
	1 x EPDM seal 1,5"	100122		
	3 x Tri-Clamp seal DN25	720201		
	1 x Tri-Clamp seal 2"	201072		
	1 x Silicon seal (levelsensor)	203021		
214518	5 x EPDM seal DN25	100123		
	1 x EPDM seal 1,5"	100122		
	5 x Tri-Clamp seal DN25	720201		
	1 x Tri-Clamp seal 2"	201072		
	1 x Silicon seal (levelsensor)	203021		



SWITCH BOXES

Designed for maximum application of the buffertank and serves as an interface between the robot and the milk tank when control with the CRS+ is insufficient or not possible.

The switch boxes are economical in price and great for simple switching. The screen illustrations shown, help select which option to use. The switch boxes are available in two performances. We have many new improved features.

Boetech standard switch boxes are equipped with the following features:

- Sharp display and fast performance. You can read the status of milk robot and buffersystem.
- Possibility to install specified alarms.
- Possibility to separate pre-cleaning and main-cleaning water.
- Possibility to check the temperature of the water from the main cleaning.



Part No.	Description
200021	<p>Standaard switch box 6-multiple valve block 50x40x15 cm</p> <p>Most common option. This switchbox must be ordered when the switch box of the main tank is able to deliver a ' tank is cleaning' signal and does not operate the optlet valve of the main tank.</p>
200010	<p>Standard switch box with Level sensor 50x40x15cm</p> <p>This switch box is the same as 200021, but this edition is able to control a level sensor and pressure system.</p>
200020	Switch box standard 5-multiple valve block
200022	Switch box double valve system
200023	<u>OPTION:</u> Tank guard module with intervalcooling
200024	<u>OPTION:</u> Tank guard module with intervalcooling and sensors to guard tank cleaning
200026	Switch box for double valve system for 2 buffer tanks.

PRESSURE SYSTEMS

With this system you can control the perssure of the milk in the buffer tank. A higher pressure in the buffer tank makes sure that all the milk will flow to the main tank. Needed if the level of the milk in the buffer tank and the level of the milk in the main tank is on the same height.



Part No.	Description
203001	Pressure system Electrical acted 3/2 valve For the: Boetech Switch box, CRS+, CRS M3
203008	Pressure system Phneumatic acted 3/2 valve For the: CRS M3

2. Tank Adjustments



Tank adjustments are designed to promote product quality and sanitation, while protecting the processing equipment.

The Boetech tank adjustment product range is wide in several ways. We have been working with dairy farmers for over 30 years to accomplish our high quality. User comfort and have always been at the core of Boetech.

The 3-way valves are the same as 2-way valves with the addition of a third port for exhausting milk. The 3-way

valve set is a complete set with a swan neck slash water damper. The swan neck with slash water damper is added value because of the reduce of slashing dirty water. This makes it unnecessary to extend the drain hose into the sewer. We use a 2" tri-clamp in the connection, so it is possible to disassemble the 3-way valve for visual inspection.

SWAN NECK

Recommended by Lely Industries, to discharge cleaning water. Stainless steel













Part No.	Description
400208	Swan neck
← 400205	Swan neck with slash water damper

3-WAY VALVES

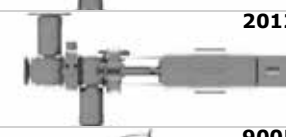
3-WAY VALVES WELDED

Pneumatically operated valves

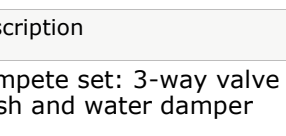
	APV	Boetech	GVS
Tank inlet 2" Melk in DN20 Drain DN20	 201546	 201185	 201095UK
Tank inlet 1,5" Melk in DN20 Drain DN20	 201087	 150201283	
Tank inlet Welded Melk in DN20 Drain DN20	 202087	 150201547	
Tank inlet 2" Melk in DN25 Drain DN25		 201388	
Tank inlet 1,5" Melk in DN25 Drain DN25		 201287	
Tank inlet Welded Melk in DN25 Drain DN25		 900546	
Tank inlet DN20 Melk in DN20 Drain DN20	 201032	 201389	
Tank inlet DN25 Melk in DN25 Drain DN25		 201392	

3-WAY VALVE WELDED COMPLETE SET

Pneumatically operated valves



Part No.	Description
201795	Complete set: 3-way valve set with swan neck slash and water damper
201095	Welded GVS 3-way valve with triclamp
400205	Swan neck with slash water damper
400365	Short milkline connector straight Pex DN20
201077	Tri-clamp DN20
201079	Sealing silicon DN20
201071	Tri-clamp 2"
201072	Sealing silicon 2"



MILK DRAIN

With our milk drain you can fill bottles, this is incl. the big nut to screw on your tank valve system. We have made our milk taper thinner, so you will have less milk loss. We have with different connections, under are some possibilities. When you want to order one, you could make a photo so that we can see which connection you need.

MILK DRAIN SWITCH

Stainless steel



Part No.	Description
200030	Milk drain switch

MILK DRAIN

Stainless steel

Part No.	Description
200036	Milk drain 2" SMS
200037	Milk drain 2" RJT
200032	Milk drain 2,5" RJT
200038	Milk drain 2,5" DN
200039	Milk drain DN80



TANK VALVE CONNECTIONS

Boetech can delivery fitted valve systems belonging to the main tank. The best tank valve system depends on the cleaning system of the main tank.

It is important to check the type of main tank accurate, to order the right type valve system, because there are a lot of different types of valve mounted on a lot of different types of min tanks. In combination with a Boetech buffer system, the hand operated tank valve is replaced by an air-assisted valve. In order to ensure highest operational safety of the valves, replace all wear parts on a regular basis.

There are two different connections:

SCREW CONNECTIONS

In general more on older main tanks



SOLID CONNECTIONS

Cleaning this is more better; no coupling, more compact. Main tanks with a built-in cleaning system are suited for solid connections. This typ is common for the newer Mueller, Packo & Delaval main tanks.



SCREW CONNECTIONS

In general more on older main tanks



- 1) Check if you need a screw or solid connection
- 2) Measure the outer diameter of the tank outlet (E)

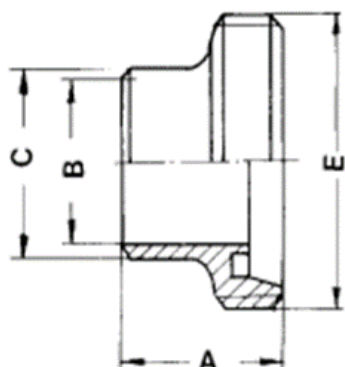

	UD buis	A	B	E
1"	25.4x1.25	29	22.9	52x1/6"
1 1/4"	31.8x1.25	32	29.3	58x1/6"
1 1/2"	38.1x1.50	33	35.1	65x1/6"
2"	50.8x1.50	35	47.8	78x1/6"
2 1/2"	63.5x1.50	40	60.2	95x1/6"
3"	76.1x1.50	40	72.8	104x1/6"
4"	101.6x2.00	54	97.4	130x1/4"

- 3) Find the correct tank connection in the table below
Tank valve systems are delivered including tri-clamp and sealing

RJT

Article nr.	Description	Bolt-to-bolt
201002	Tank valve connection RJT 2"	72 mm
201001	Tank valve connection RJT 2,5"	85 mm
201003	Tank valve connection RJT 3"	98 mm
201005	Air actuator Universal	
100070	Mounting bracket air acuator universal 2"	
100071	Mounting bracket air acuator universal 2,5"	
100072	Mounting bracket air acuator universal 3"	

SMS

Article nr.	Description	Bolt-to-bolt
201012	Tank valve connection SMS 2"	70mm
201005	Air actuator SMS Universal	
100070	Mounting bracket air acuator universal 2"	

Clamp

Article nr.	Description	Bolt-to-bolt
	Tank valve connection Clamp 1,5"	50mm
201023	Tank valve connection Clamp 2"	64mm
201026	Tank valve connection Clamp 2,5"	77mm
201005	Air actuator SMS Universal	
100070	Mounting bracket air acuator universal 2"	
100071	Mounting bracket air acuator universal 2,5"	

DIN11851

Article nr.	Description	Bolt-to-bolt
201031	Tank valve connection DIN11851 DN65	95mm
201622	Tank valve connection DIN11851 DN80	110mm
201022	Tank valve connection DIN11851 2"	78mm
201005	Air acuator Universal	
100070	Mounting bracket air acuator universal 2"	
100073	Mounting bracket air acuator universal DN80	

SOLID CONNECTION

typ is common for the newer Mueller, Packo & Delaval main tanks



- 1) Check if you need a screw or solid connection
- 2) Measure the bolt-to-bolt distance (A)



Sealing form 'Trapezium'



Sealing form 'Slantwise'

- 3) When needed a M&S, check the sealing form.
- 4) Find the correct tank connection in the table below
Tank valve systems are delivered including tri-clamp and sealing.

M&S

Article nr.	Description	Sealing	Bolt-to-bolt
201110	Tank valve connec. M&S 2" TYP 95	Trapezium	67mm
231110	Tank valve connec. M&S 2" TYP 95 double X		67mm
251022	Tank valve connec. M&S 2" type 95 welded		67mm
201111	Tank valve connec. M&S 2" TYP 98	Slantwise	67mm
201120	Tank valve connec. M&S 2,5" TYP 95	Trapezim	79mm
231120	Tank valve connec. M&S 2,5" TYP 95 double X		79mm
201125	Tank valve connec. M&S 3" TYP 95		90mm
201128	Tank valve connec. M&S DN80 TYP 95		
201130	Tank valve connec. M&S DN80 TYP 98	Slantwise	

M&S

Article nr.	Description	Bolt-to-bolt
201005	Air actuator Universal	
100070	Mounting bracket air acuator universal 2"	
100071	Mounting bracket air acuator universal 2,5"	
100072	Mounting bracket air acuator universal 3"	
100073	Mounting bracket air acuator universal DN80	

LKB (Delaval tanks)

Article nr.	Description	Bolt-to-bolt
201210	Tank valve connection LKB 2"	61mm
201220	Tank valve connection LKB 2,5"	72mm
201221	Tank valve connection LKB 2,5" double X	72mm
241220	Tank valve connection LKB 2,5" double parallel	72mm
201230	Tank Valve System LKB 3"	80mm
251230	Tank valve connection New LKB 3"	
720184	Tank valve connection New LKB 3" Inlet 1,5"	
201232	Tank valve connection LKB 3" double X	80mm
201235	Tank valve connection LKB 3" double parallel	80mm
201280	Air actuator Alfa Laval 2-2,5"	
720091	Mounting bracket air acuator Alfa Laval 2-2,5"	
201281	Air actuator Alfa Laval 3"	
720092	Mounting bracket air acuator Alfa Laval 3"	

Kieselmann (Packo tanks)

Article nr.	Description	Bolt-to-bolt
201320	Tank valve connection Kieselmann DN65	78mm
201321	Tank valve connection Kieselmann DN65 double X	78mm
201310	Tank valve connection Kieselmann DN50	65mm
201330	Tank valve connection Kieselmann DN80	88mm
201380	Air actuator Kieselmann	
7660006	Mounting bracket Kieselmann DN15-DN50	
7660007	Mounting bracket Kieselmann DN65-DN80	

Definox (Westfalia/Japy tanks)

Article nr.	Description	Outside inner pipe
201053	Tank valve connection Definox DN50 (4 bolts)	52mm
201052	Tank valve connection Definox DN50 double X	52mm
201054	Tank valve connection Definox DN65 (6 bolts)	
201057	Tank valve connection Definox DN65 double X	
201321	Tank valve connection Definox DN65	
201172	Tank valve connection Definox 3"	
201063	Air actuator Definox DN20-DN80-3" incl. bracket	

APV

Article nr.	Description	Bolt-to-bolt
201103	Tank valve connection APV 3" 6 bolts	65mm
201104	Tank valve connection APV 3" 6 bolts X-Piece	65mm
720126	Air acuator APV	
702127	Mounting bracket air acuator APV	

Tassalini

Article nr.	Description	Bolt-to-bolt
201029	Tank valve connection Tassalini 2"	
201027	Tank valve connection Tassalini 2,5"	
720334	Air actuator Tassalini 2" incl. brakcet	
722018	Air actuator Tassalini 2,5" incl. brakcet	

Needing help?

We will assess which solution is most suited for your situation.
Email: sales@boetech.nl

Include the following in your email:

- 1) The dimensions of the outer diameter (A+B)
- 2) The dimensions of the inner pipe (C)
- 3) A picture of the FROUNT + SIDE + TOP
- 4) A picture of the main tank
- 5) Text on tank valve
- 6) Sealing form: Trapezium or Slantwise

Observe the safety data sheets by the cleaning agent manufacturers! Only use cleaning agents that do not attack stainless steel, elastomer not plastic.

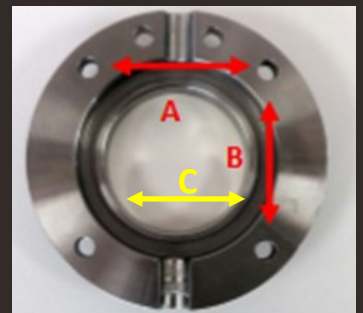

3. Milk pipeline connectors

Boetech offers you three types of connectors: Clamp, Pex and Silicon.

The milk pipeline is an important component of a dairy farm milking operation, which is used to transfer milk from the milk robot to the storage tank. Boetech produces high quality, inexpensive and reliable milk line connectors.

Boetech connectors have the right shape and no sharp edges on the inside. They are long and have a big diameter, to provide a secure fit while maintaining an excellent flow. The stainless steel material guarantees a long service life and it is very hygienic. PEX pipe is a flexible cross-linked polyethylene tubing.



The pipeline and all milk handling systems are cleaned after every milking session using a washing system that first rinses out the remaining milk and then flushes cleaning solution through the piping to kill

bacteria and remove milk stone. The inside of the Boetech milk pipeline connectors is conical. There is less resistance which is better for the milk quality and more hygienic.



CLAMP CONNECTOR





PEX CONNECTOR



SILICON CONNECTOR





DN20 Straight connectors

Stainless steel

Article nr.		Description
400364		Clamp DN20 - Clamp DN20 straight
400365		Clamp DN20 - Pex DN20 straight
400367		Pex DN20 - Pex DN20 straight



DN20 90° Elbow connectors

Stainless steel

Article nr.		Description
400366		Clamp DN20 - Pex DN20 90°
400369		Clamp DN20 - Clamp DN20 90°
400319		Clamp DN20 - for welding
400387		Pex DN20 - Pex DN20 90°



DN20 180° connectors

Stainless steel

Article nr.		Description
400180		Clamp DN20 - Clamp DN20 180°
400190		Clamp DN20 - Pex DN20 180°



DN20 Y-piece

Stainless steel

Article nr.		Description
400351		Y-piece 3x Clamp DN20
400361		Y-piece 3x Pex DN20



DN20 Parallel piece connectors

Stainless steel

Article nr.		Description
401372		Parallel T-piece 3x Clamp DN20
401371		Parallel T-piece 3x Pex DN20





DN20 T-piece connectors

Stainless steel

Article nr.		Description
400352		T-piece 3x Clamp DN20
400362		T-piece 3x Pex DN20



DN20 Spare parts

Interchangeable part used for repair or replacement

Article nr.		Description
400360		Pex tule DN20
201077		Tri-Clamp DN20
201079		Sealing ring DN20
9999164		Hose clamp Pex DN20





DN25 Straight connectors

Stainless steel

Article nr.		Description
425004		Clamp DN25 - Clamp DN25 straight
425001		Clamp DN25 - Pex DN25 straight
425367		Pex DN25 - Pex DN25 straight



DN25 90° Elbow connectors

Stainless steel

Article nr.		Description
425003		Clamp DN25 - Pex DN25 90°
400322		Clamp DN25 - for welding
425042		Clamp DN25 - Clamp DN25 90°
425002		Pex DN25 - Pex DN25 90°



DN25 180° connectors

Stainless steel

Article nr.		Description
425180		Clamp DN25 - Clamp DN25 180°
425190		Clamp DN25 - Pex DN25 180°



DN25 Y-piece connectors

Stainless steel

Article nr.		Description
425351		Y-piece 3x Clamp DN25
425361		Y-piece 3x Pex DN25



DN25 Parallel piece connectors

Stainless steel

Article nr.		Description
425353		Parallel T-piece 3x Clamp DN25
425363		Parallel T-piece 3x Pex DN25





DN25 T-piece connectors

Stainless steel

Article nr.		Description
425352		T-piece 3x Clamp DN25
425362		T-piece 3x Pex DN25



DN25 Spare parts

Interchangeable part used for repair or replacement

Article nr.		Description
400380		Pex tube DN25
720153		Tri-Clamp DN25
720201		Sealing ring DN25
9999165		Hose clamp Pex DN25



Silicon Straight connectors

Stainless steel

Article nr.		Description
400368		Clamp DN20 - Silicon straight
400310		Pex DN20 - Silicon straight
425310		Pex DN25 - Silicon straight





Silicon 90° Elbow connectors

Stainless steel

Article nr.		Description
201066		Clamp DN20 - Silicon 90°
425041		Clamp DN25 - Silicon 90°



DN20 Spare parts

Interchangeable part used for repair or replacement

Article nr.		Description
400370		Connector Silicon
9999168		Hose clamp Silicon DN20
201077		Tri-Clamp DN20
201079		Sealing ring DN20



Other Straight connectors

Stainless steel

Article nr.		Description
201400		Clamp DN20 - Clamp DN25 straight
425341		Pex DN20 - Clamp DN25 straight
425342		Pex DN20 - Pex DN25 straight



Other 90° connectors

Stainless steel

Article nr.		Description
401352		Pex DN20 - Clamp DN25 90°
401354		Pex DN20 - Pex DN25 90°





Other Y-piece connectors

Stainless steel

Article nr.		Description
401351		Y-piece 2x Clamp DN20 - Clamp DN25
402351		Y-piece 2x Pex DN20 - Pex DN25
426363		Y-piece Pex DN25 - Pex DN20 to Pex DN25



Other T-piece connectors

Stainless steel

Article nr.		Description
402352		T-piece 2x Clamp DN20 - Clamp DN25
402362		T-piece 2x Pex DN20 - Pex DN25
402363		T-piece 1x Pex DN20 - 1x Pex DN25 to Pex DN25
426362		T-piece 1x Pex DN25 - 1x Pex DN20 to Pex DN25





Other Parallel piece connectors

Stainless steel

Article nr.		Description
401356		Parallel T-piece 2x Clamp DN20 - Clamp DN25
401307		Parallel T-piece 2x Pex DN20 - Clamp DN25
401376		Parallel T-piece 2x Pex DN20 - Pex DN25

Spare parts

Interchangeable part used for repair or replacement

Article nr.		Description
201077		Tri-clamp DN20
720153		Tri-clamp DN25
201079		Sealing ring DN20
720201		Sealing ring DN25



4. Between Robot and Tank

DUO FILTERS

Filtration is one of the key processes to protecting milking and cooling equipment. The duo filter is a device that removes particles from the raw milk before getting pumped into the milk tank.

A duo filter consists of two filter housings both holding a filter sock that filters the milk before getting pumped into the milk tank. The filter automatically switches to the clean filter at the right time during main cleaning of the main tank. Available in a left and right model. All milk filters meet the Dutch Food Standard regulations.

The robust frame is specially designed and is based on performance testing. More robots can be managed through one duo filter, saving you extra filters. With the duo filters you have more time in between cleanings to replace the filter, compared with a single filter. This allows you to replace when it suits you.

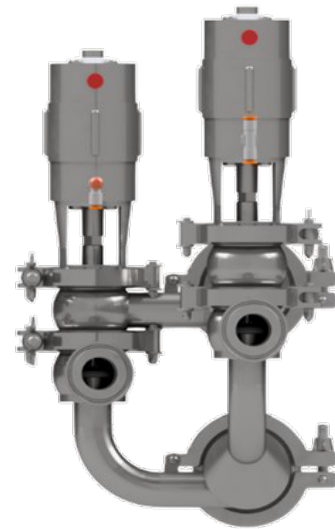

ADVANTAGES

- Easy to install. Duo milk filters are ready and mounted into the milk line.
- Provides high quality milk to dairy processors
- User-friendly design makes changing the filters easy

Duo filter Milk in left

Stainless steel



Part No.	Description
500621	Duo filter DN20
500620	Duo filter DN25
500622	Duo filter 1"

Duo filter Milk in right

Stainless steel



Part No.	Description
510621	Duo filter DN20
510620	Duo filter DN25
510622	Duo filter 1"

Wall brackets Duo filter

Stainless steel

Part No.	Description
510700	Duo Wall Bracket milk in left
511700	Duo Wall Bracket milk in right

Recommended product to combine with the Non-return valves.

Less water residue after cleaning results in **lower freezing point** in main tank. Less water will remain in the Duo filter.

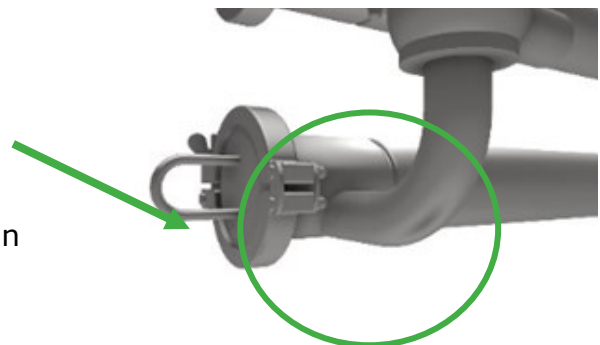

WATER SYSTEMS

It is important to use an effective water system in your barn. We have designed water systems to reuse the water from your pipe heat exchanger. The water valve systems have rapid return on your investment. Boetech can offer you three water systems.

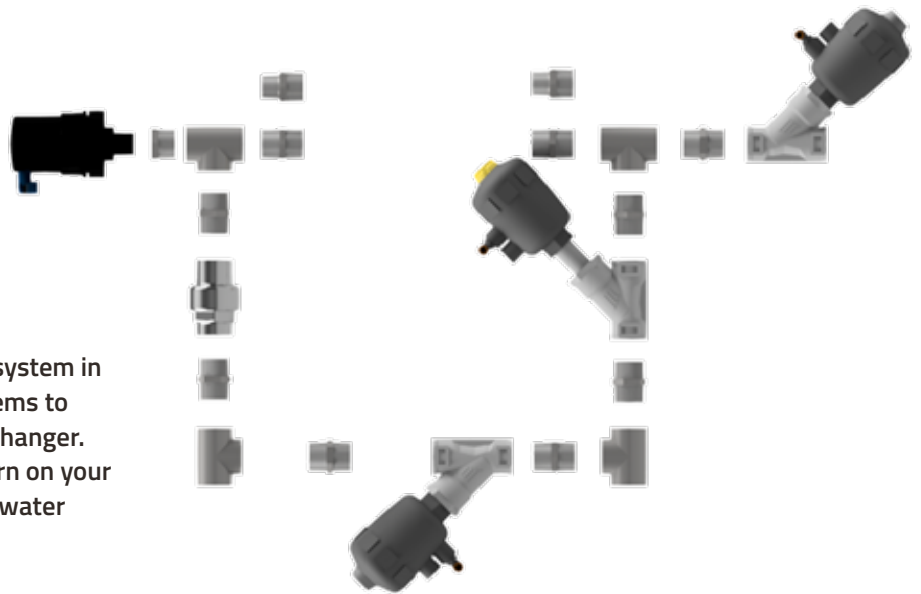

1. WATER CONTROL SYSTEM

With this controlled water system, the water used in your pipe heat exchanger is pumped to the water storage vessel and stored in it. After this, the water will gradually enter the water troughs.

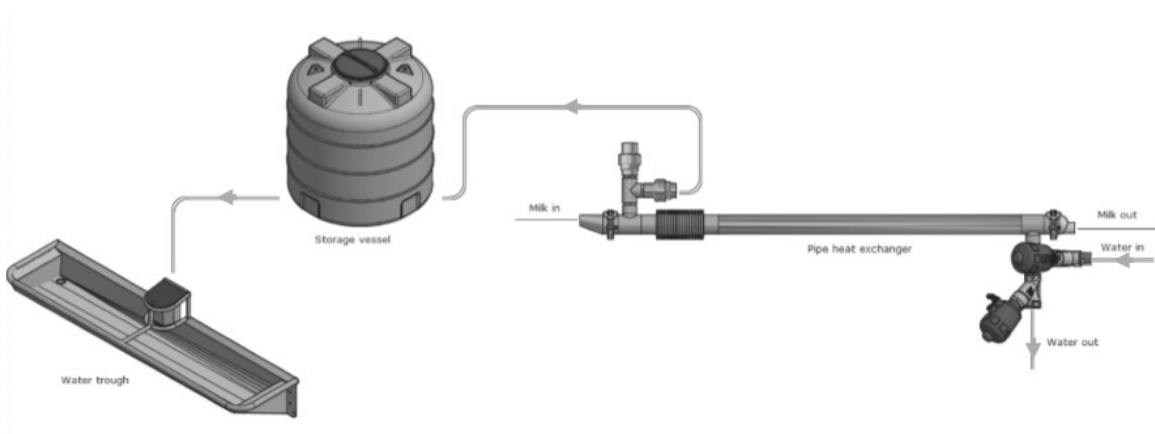

Water control system parts

Article nr.	Description
300930	Water control system
	Set parts
100209	Non-return valve
720177	T-piece 1"
720172	Threaded socket 1"
300910	NC Water valve
720075	Threaded socket 1" - 3/4"
701251	4mm air tube connector 90°

2. BYPASS WATER SYSTEM

With a bypass water system in your barn you have a continuous flow of water. This will prevent freezing of pipelines. Due to the opposite flow of water and milk, optimum use is made of the cooling system of the pipe heat exchanger. With this water system, the used water from your pipe heat exchanger is reused in the water troughs.

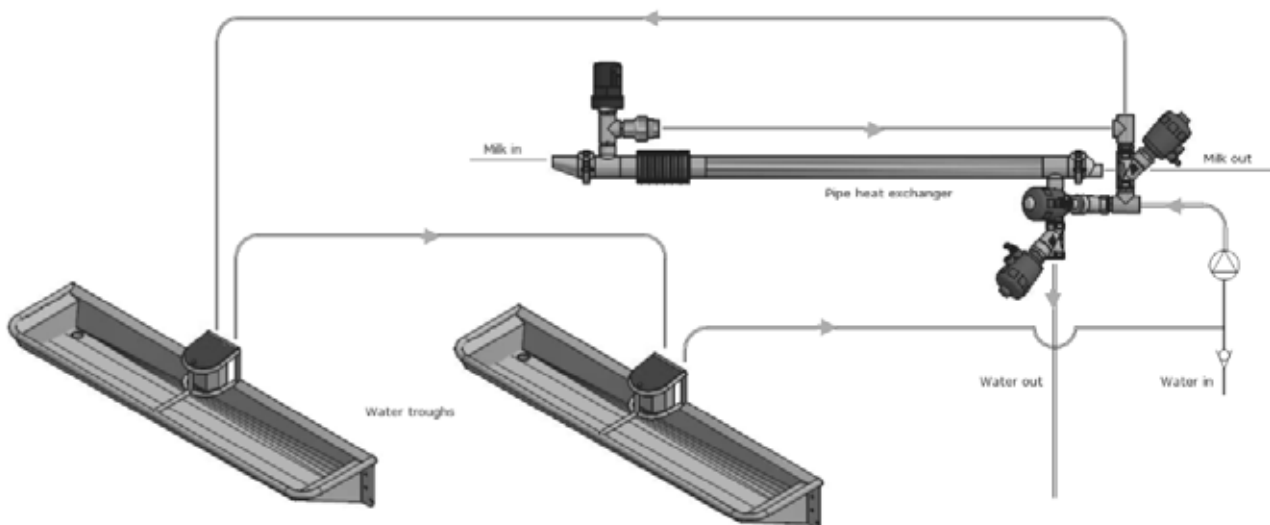

Bypass water system parts

Article nr.	Description
300940	Water control system
	Set parts
100209	Non-return valve
720177	T-piece 1"
720172	Threaded socket 1"
300910	NC Water valve
720075	Threaded socket 1" - 3/4"
701251	4mm air tube connector 90°
701220	4mm air tube connector t-piece
720173	Threaded socket 1" internally—3/4 external
100202	Air inlet valve

3. BYPASS WATER SYSTEM 2.0

With a bypass water system in your barn you have a continuous flow of water. This will prevent freezing of pipelines. With this water system the used water from your heat exchanger gets reused in one of your water troughs. The rest of your water troughs will get fresh, cold water. Because of the extra valve, this system ensures that no lukewarm water returns in the pipe heat exchanger.

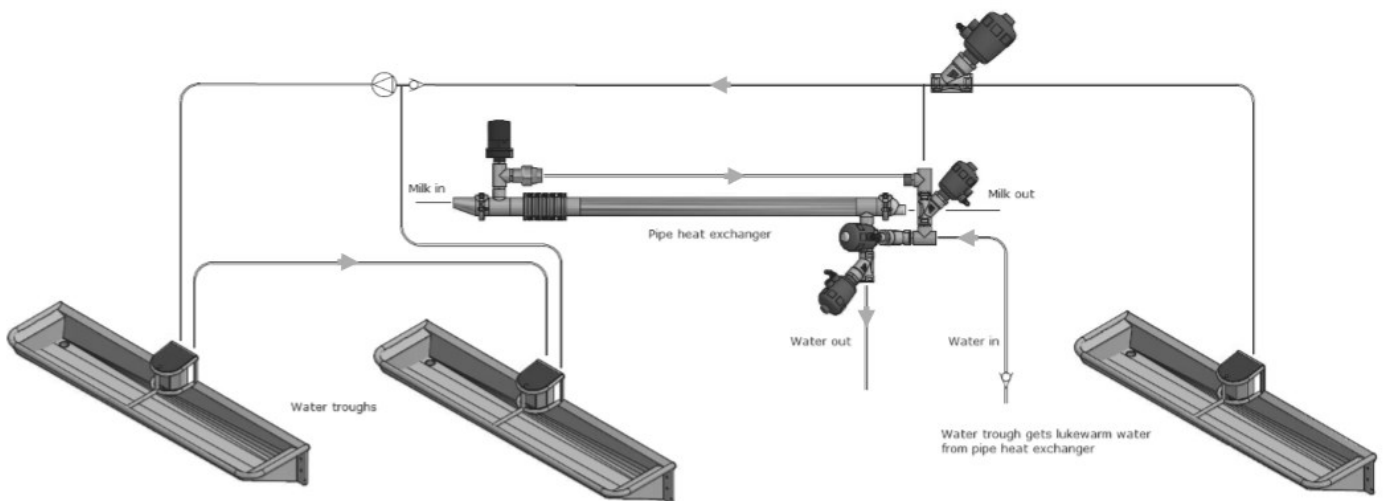

Bypass water system 2.0 parts

Article nr.	Description
300945	Water control system
	Set parts
100209	Non-return valve
720177	T-piece 1"
720172	Threaded socket 1"
300910	NC Water valve
720075	Threaded socket 1" - 3/4"
701251	4mm air tube connector 90°
701220	4mm air tube connector t-piece
720173	Threaded socket 1" internally—3/4 external
100202	Air inlet valve

NON-RETURN VALVE

Boetech supplies Non-return valves for reliable protection against reverse milk flow, from the main tank to the milk robot.

The non-return valve is fitted to ensure that the milk flows trough in the right direction, where pressure conditions may otherwise cause reversed flow. The opening force is dependent on the pressure, the closing force is dependent on the tension of the closing springs.

When the milk is pumped through the milk line, the non-return valve is opened and will deform in the stainless steel housing. The non-return does not close completely. This causes milk leakage on the non-return valve.



Non-return valves

Stainless steel. Recommended product to combine with the Duo-filter



Part No.	Description
201414	Non-return valve Silicon - welded DN20
201414/750	Non-return valve Silicon 750 mm pipe - Pex DN20



PIPE HEAT EXCHANGER

Energy efficient milk cooling with the pipe heat exchanger. Cooling your milk while saving energy and reusing the lukewarm water for your cattle.

The quicker the milk is cooled after milking, the better the quality when it is collected from the farm. The pipe heat exchanger cools the milk before it reaches the main storage tank. Cold water and warm milk flow in separate systems thru the pipe heat exchanger. Because you cool the milk down fast, the bacterial growth will immediately drop giving you more certainty on healthy milk.

The pipe heat exchangers are available in the 3m and 6m. The 6m has 7x mm internal stainless steel pipes, the 3m has 19xmm internal stainless steel pipes. Put the pipe heat exchanger in the cable rails or mount is on the wall with the wall brackets.

ADVANTAGES

- Easy to install. Duo milk filters are ready and
- The inside is a closed system. There is no milk bleeding risk.
- Suitable for all milk quantities.
- Significant savings on the overall milk cooling process and efficient use of energy.
- Improves milk quality. High quality milk has a longer shelf life and can be processed into more high value products.
- Lukewarm 'wastewater' from the pipe heat exchanger can be used for the water troughs.



Pipe heat exchanger

Stainless steel



Part No.	Description
400530	Pipe heat exchanger 6m 7in1
430931	Pipe heat exchanger 3m 19in1

Wall brackets Pipe heat exchanger

Stainless steel brackets with 4 holes. Does not come with the pipe heat exchanger.



Part No.	Description
66660536	Wall brackets Tube cooler 6m 7in1
66660539	Wall brackets Tube cooler 3m 19in1

Install the pipe heat exchanger nearby the milk robot. Make sure the milk goes trough the filter first before it enters the pipe heat exchanger. Their has to be a counter flow of milk and water stream.

Possibilities in endings:

6m 7in1		3m 19in1	
	400537 DN20 Pex Eccentric		66660639 DN20 Pex Eccentric
	400539 DN25 Pex Eccentric		66660640 DN25 Pex Eccentric
	400535 DN20 Clamp Eccentric		66660637 DN20 Clamp Eccentric
	400534 DN25 Clamp Eccentric		66660638 DN25 Clamp Eccentric
	400536 DN20 Weld Eccentric		66660635 DN20 Weld Eccentric
	400538 DN25 Weld Eccentric		66660636 DN25 Weld Eccentric
	401537 DN20 Pex Blind		66670639 DN20 Pex Blind
	401539 DN25 Pex Blind		66670640 DN25 Pex Blind
	401535 DN20 Clamp Blind		66670637 DN20 Clamp Blind
	401534 DN25 Clamp Blind		66670638 DN25 Clamp Blind
	401536 DN20 Weld Blind		66670635 DN20 Weld Blind
	401538 DN25 Weld Blind		66670636 DN25 Weld Blind

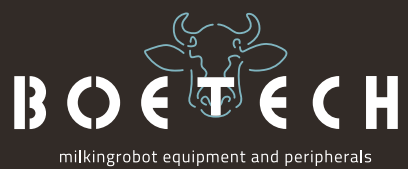

Antennestraat 38
1322 AE Almere

sales@boetech.nl
+31 854 89 8410

boetechmeps.com